

RELIEF VALVE

CPLN-020-DPNA

**DIRECT ACTING
STABILIZED PISTON**

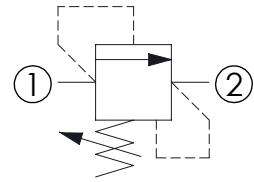
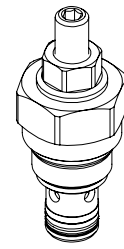
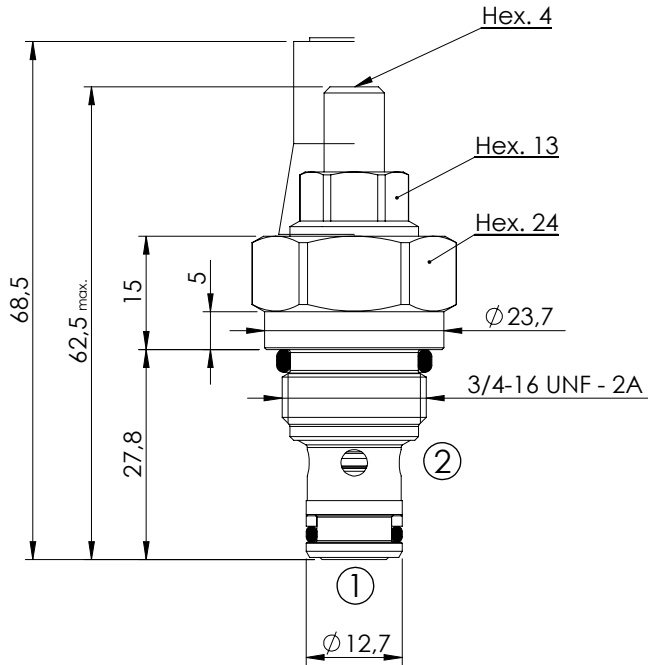

SPECIFICATIONS

Max. operating pressure:	420 bar
Rated flow:	20 l/min
Cavity:	SAE-08-2N
Weight:	0,1 kg

SEALING CAP

Ordering code:
AT000020

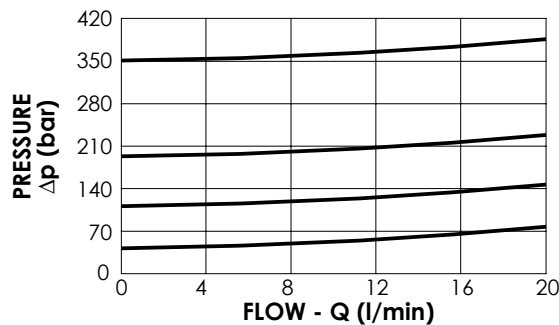
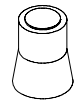

NOTES

Installation torque:	45-50 Nm
Seal kit:	RA700081

ORDERING CODES

Quick code	Description	Standard setting (bar, Q=5 l/min)	Adjustment range (bar)	Pressure increase (bar/turn)
CP000168	CPLN-020-DPNA-SN-S08-N420	350	200-420	207
CP000025	CPLN-020-DPNA-SN-S08-N350	350	175-350	177
CP000007	CPLN-020-DPNA-SN-S08-N200	200	105-210	80
CP000028	CPLN-020-DPNA-SN-S08-N100	100	35-140	49
CP000027	CPLN-020-DPNA-SN-S08-N050	50	10-70	26