

RELIEF VALVE WITH REVERSE FREE FLOW

CPAN-090-DHGA

DIRECT ACTING
STABILIZED PISTON

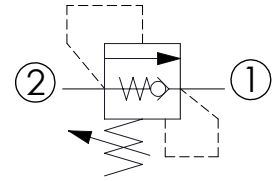
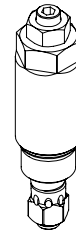
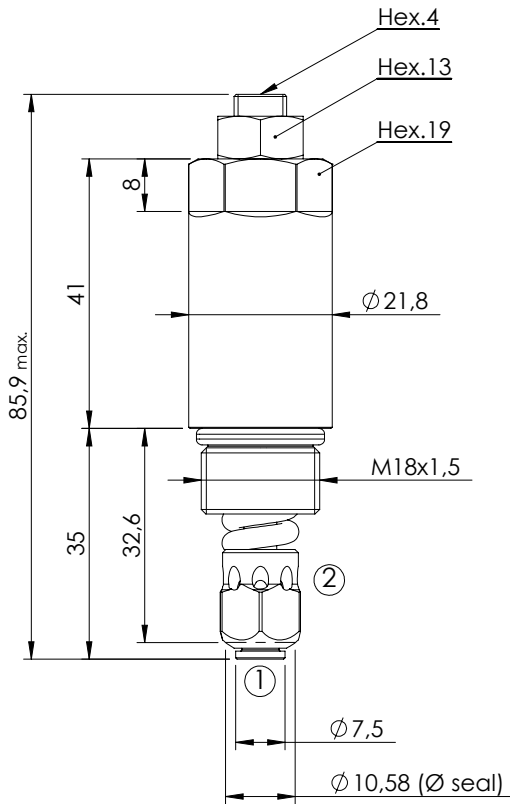

SPECIFICATIONS

Max. operating pressure:	380 bar
Rated flow:	90 l/min
Cavity:	VP000249
Weight:	0,15 kg

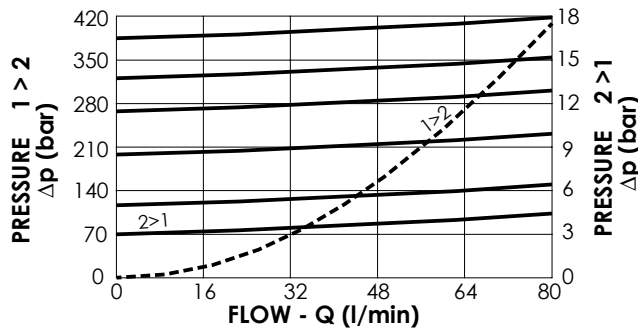

NOTES

Installation torque:	40 - 45 Nm
Seal kit:	RC900249

ORDERING CODES

Quick code	Description	Standard setting (bar, Q=5 l/min)	Adjustment range (bar)	Pressure increase (bar/turn)
CP000114	CPAN-090-DHGA-HN-249-N380	380	320 - 380	101
CP000113	CPAN-090-DHGA-HN-249-N320	320	270 - 320	67
CP000109	CPAN-090-DHGA-HN-249-N270	270	200 - 270	44
CP000112	CPAN-090-DHGA-HN-249-N200	200	120 - 200	30
CP000111	CPAN-090-DHGA-HN-249-N120	120	70 - 120	18
CP000122	CPAN-090-DHGA-HN-249-N070	70	10 - 70	8