

RELIEF VALVE

CPLN-160-DHGA

**DIRECT ACTING
STABILIZED PISTON**

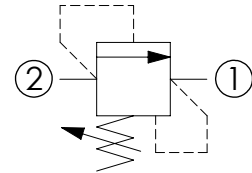
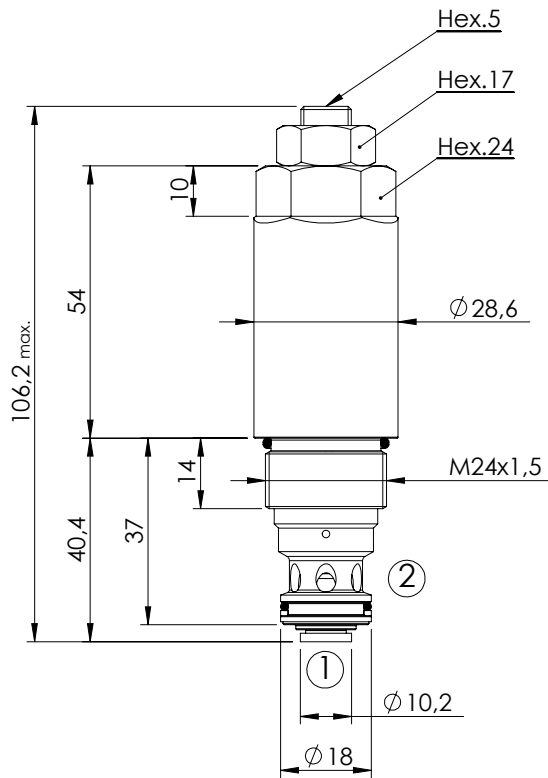

SPECIFICATIONS

Max. operating pressure:	400 bar
Rated flow:	160 l/min
Cavity:	VP000250
Weight:	0,33 kg

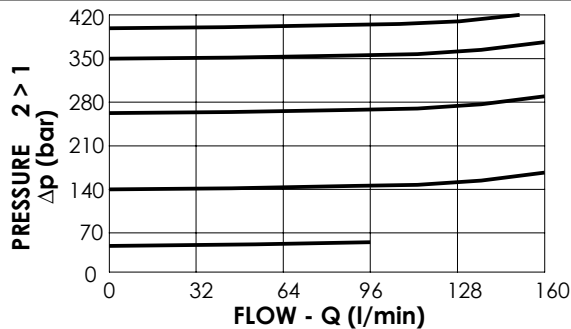

NOTES

Installation torque:	45 - 50 Nm
Seal kit:	RC900250

ORDERING CODES

Quick code	Description	Standard setting (bar, Q=5 l/min)	Adjustment range (bar)	Pressure increase (bar/turn)
CP000108	CPLN-160-DHGA-HN-250-N400	400	350 - 400	72
CP000107	CPLN-160-DHGA-HN-250-N350	350	270 - 350	58
CP000100	CPLN-160-DHGA-HN-250-N270	270	140 - 270	49
CP000106	CPLN-160-DHGA-HN-250-N140	140	90 - 140	36
CP000121	CPLN-160-DHGA-HN-250-N090	90	50 - 90	13